

Battery pack for the Parklio™ Gate

User manual

Trademarks

Parklio™ is a trademark of Amplifico d.o.o.

Other brand and product names are registered trademarks or trademarks of their respective holders.

Statement of Conditions

In the interest of improving internal design, operational function, and/or reliability, Parklio™ reserves the right to make changes to the products described in this document without notice. Parklio™ does not assume any liability that may occur due to the use or application of the product(s) or circuit layout(s) described herein.

Thank you for the confidence you have shown us by purchasing our product!



Parklio | Smart parking solutions

e: info@parklio.com | **w:** www.parklio.com

m: + 385 97 724 7276

Please read this manual first!

Dear Customers,

We hope that all your expectations of this product will be fulfilled. Every Parklio™ product is manufactured using the latest technologies and has undergone rigorous quality control procedures.

The User Guide will help you use your product quickly and safely.

Read the user manual before installing and using your product.

Always follow the safety instructions.

Keep this user manual at hand for future reference.



Parklio | Smart parking solutions

e: info@parklio.com | **w:** www.parklio.com

m: + 385 97 724 7276

Table of Contents

Important remarks	6
Description and intended use	7
Installation	8
Electrical connections	9
Indications	11
Checking function and testing	12
Replacing the batteries	13
Replacing the fuse	14
Technical characteristics	15
Disposal	16



Parklio | Smart parking solutions

e: info@parklio.com | **w:** www.parklio.com

m: + 385 97 724 7276

1. Important remarks

For any installation problem please contact our Customer Service.

Parklio has the right to modify the product without previous notice; it also declines any responsibility to damage or injury to people or things caused by improper use or wrong installation.



Please read this instruction manual very carefully before installing and programming your control unit.

- This instruction manual is only for qualified technicians, who specialize in installations and automations.
- The contents of this instruction manual do not concern the end user.
- Every programming and/or every maintenance service should be done only by qualified technicians.

The installation, testing and commissioning of door and gate automation devices must be performed by qualified and skilled personnel, who must assume responsibility for setting up the tests envisaged depending on the risks present; and verify compliance in accordance with legal and regulatory requirements.

- Parklio are not deemed responsible for injuries and damage resulting from improper use of the product; other than that envisaged in this manual.
- Packing materials must be disposed of in full compliance with local regulations.
- Ensure that the back-up battery cannot become immersed in water or other liquids.
- Should any liquids penetrate inside the device, disconnect it immediately from the automation device and contact the V2 assistance service; use of the device under such conditions can lead to hazardous situations.
- Do not store the back-up battery close to strong sources of heat or expose it to naked flames; such actions can damage it and be the cause of malfunctions, fire or other hazardous situations
- In order to avoid the risk of leakage of hazardous substances from the back-up battery in the case where the device is not used for long periods of time, it is preferable to disconnect it from the automated device and store it in a dry place.



Parklio | Smart parking solutions

e: info@parklio.com | **w:** www.parklio.com

m: + 385 97 724 7276

2. Description and intended use

The battery pack can only be installed in Parklio Gates; it allows the accumulation of energy during the period in which the automated device is powered from the mains supply and to return it in the case of a mains power failure. The number of opening cycles possible during a power failure depends on the power consumption of the automated device and varies between a few tens to a hundred or so opening operations.



Parklio | Smart parking solutions

e: info@parklio.com | **w:** www.parklio.com

m: + 385 97 724 7276

3. Installation

⚠ PLEASE NOTE: battery pack installation operations must be conducted with the system disconnected from the mains supply. If the battery pack is installed inside a motor, follow the instructions with the motor regarding the correct positioning and connection of the device. If the battery pack is installed outside a motor, in an environment exposed to bad weather, it is essential the device be installed inside a water-tight container.

If the battery pack is installed inside of a Parklio gate, follow the instructions in the chapter 8.2 of the Parklio Gate user manual.

If the battery pack is installed outside a motor, in an environment exposed to bad weather, it is essential the device be installed inside a water-tight container as shown in figure 3.1.

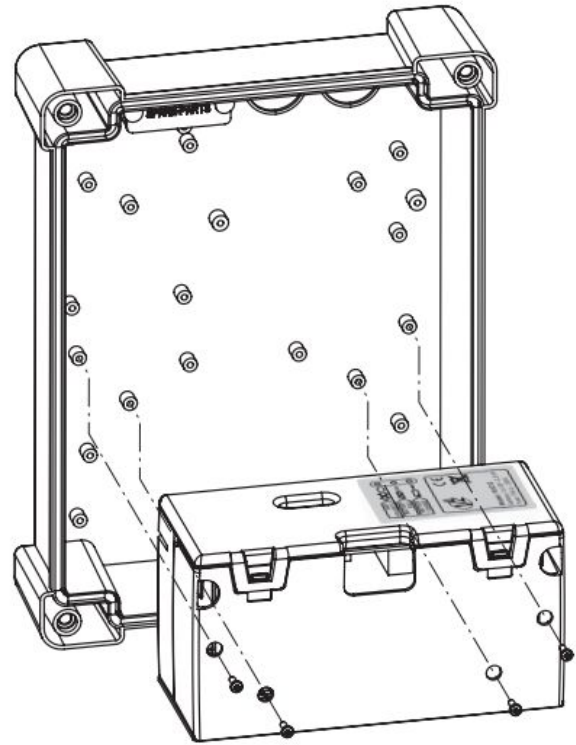

Figure 3.1 - Battery pack installation in the waterproof enclosure



Parklio | Smart parking solutions

e: info@parklio.com | **w:** www.parklio.com

m: + 385 97 724 7276

4. Electrical connections

1. The device is supplied with the internal battery cables disconnected; perform the connection operations by following the diagram in figure 4.1.
2. Connect the battery pack to the control unit by inserting the polarised connector **A** in the dedicated faston socket on the control unit.
3. If the cable is too short, use the extension provided:
 - a. insert the polarised connector **C** into the dedicated faston socket on the control unit
 - b. bring the extension cable to the battery pack
 - c. fit connector **B** by crimping the two fastons on the extension cable

PLEASE NOTE: Insert the fastons into the connector while observing the polarity of the cable coming from the battery pack

- d. insert connector **A** into connector **B** as shown on figure 4.2

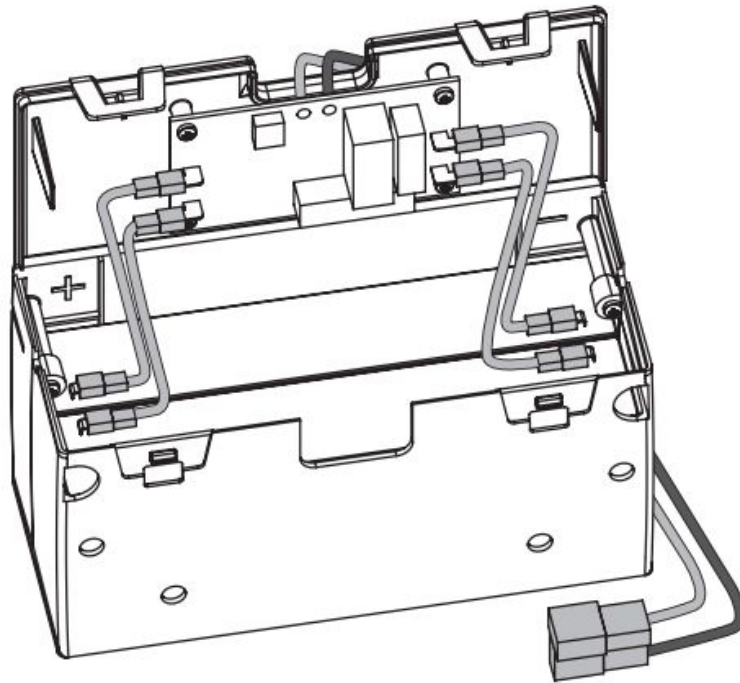

Parklio | Smart parking solutions

e: info@parklio.com | **w:** www.parklio.com

m: + 385 97 724 7276

Figure 4.1 - Connection of the internal cables

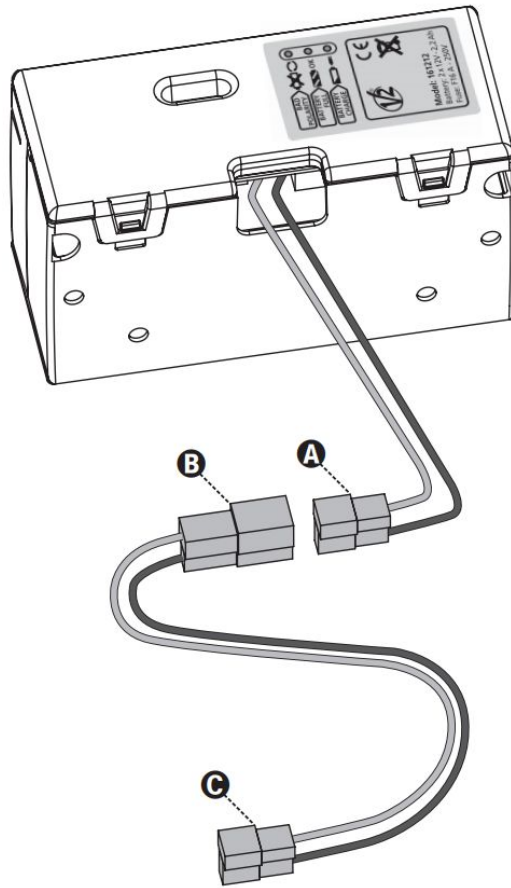

Figure 4.2 - Connection of the internal cables



Parklio | Smart parking solutions

e: info@parklio.com | **w:** www.parklio.com

m: + 385 97 724 7276

5. Indications

The status of the battery pack is displayed by means of 3 LEDs:

- Yellow LED: charging
- Green LED: fully charged
- Red LED: at least one battery has been connected wrong

In the case of a blackout, the battery charger automatically switches from recharge mode to back-up power supply mode (all LEDs are off); on restoration of mains power, the battery charger switches once more and the yellow LED comes on to indicate that battery charging is ongoing.

 **PLEASE NOTE: during battery charging, the cover of the battery charger can become hot; this is normal, and should not cause any concern.**



Parklio | Smart parking solutions

e: info@parklio.com | **w:** www.parklio.com

m: + 385 97 724 7276

6. Checking function and testing

The following checks are performed immediately after having connected the battery to the control unit:

1. Check that the control unit is on (with mains power disconnected): the battery pack LEDs remain off.
2. Connect the automation device to the mains supply and check that the YELLOW LED is on, indicating that the battery is recharging correctly.
3. Disconnect the automation device from the mains supply; check that the YELLOW LED is off, then perform at least one automated device opening and closing manoeuvre, in order to verify that everything is operating perfectly, even in the case of battery operation.

Please note: depending on the type of automation device, movements might occur at reduced speed when the back-up battery is in operation.

4. On completion of the tests, reconnect the automation device to the mains supply.



Parklio | Smart parking solutions

e: info@parklio.com | **w:** www.parklio.com

m: + 385 97 724 7276

7. Replacing the batteries

The battery pack does not require any maintenance, however, it is appropriate to disconnect it from the automation device during prolonged periods without use, and store it in a dry place.

Replacement of the accumulators becomes necessary when battery life is significantly reduced due to ageing. In any case, it is recommended that replacement take place after five years of use.

To replace the batteries, proceed as follows:

1. Disconnect the cable to the control unit
2. Open the casing, using a screw-driver as a lever
3. Disconnect the batteries
4. Push through the through-hole in the base of the casing to remove the battery
5. Manoeuvre the internal battery over the hole and push it out
6. Insert the first battery with the positive pole to the left and manoeuvre it into position
7. Always insert the second battery with the positive pole to the left
8. Connect the yellow cables to the poles of the batteries (take care not to cross them); should the red LED come on, it means that one of the batteries is the wrong way round
9. Reclose the casing
10. Reconnect the cable to the control unit

 **PLEASE NOTE: Always replace both batteries with new batteries of the same model. NEVER mix new and old batteries at the same time.**

 **PLEASE NOTE: The accumulators contain lead and other pollutants; certain electronic components may contain pollutants: do not dispose of them with normal waste, but use the methods envisaged under local regulations.**



Parklio | Smart parking solutions

e: info@parklio.com | **w:** www.parklio.com

m: + 385 97 724 7276

8. Replacing the fuse

Should the device stop unexpectedly, check the fuse is intact; if the fuse is blown, replace it according to the instructions below:

1. Disconnect the cable to the control unit
2. Open the casing, using a screw-driver as a lever
3. The electronic circuit board is fixed inside the cover; identify the fuse and replace it with one of the same rating (F16A)
4. Reclose the casing
5. Reconnect the cable to the control unit



Parklio | Smart parking solutions

e: info@parklio.com | **w:** www.parklio.com

m: + 385 97 724 7276

9. Technical characteristics

Batteries	2 x 12V / 2,2Ah
Fuse	F16A
Operating temperature	0°C - +40°C charging -20°C - +50°C in use
Dimensions	195mm x 96mm x 78mm
Weight	1600g

Table 9.1 - Technical Characteristics



Parklio | Smart parking solutions

e: info@parklio.com | **w:** www.parklio.com

m: + 385 97 724 7276

10. Disposal

As for the installation, the disposal of the product at the end of its effective life must be performed by qualified personnel.

This product is made of various types of material, some of which can be recycled while others must be disposed of.

Enquire about the recycling or disposal systems available for this product category in compliance with regulations locally in force.



Parklio | Smart parking solutions

e: info@parklio.com | **w:** www.parklio.com

m: + 385 97 724 7276